

## THE EFFECT OF THE READING CORNER PROGRAM ON INCREASING READING INTEREST

Fauzan Juliansyah<sup>1\*</sup>, Diki Rukmana<sup>2</sup>

<sup>1,2</sup>University of Muhammadiyah Prof. Dr. Hamka

<sup>1</sup>fznsyah307@gmail.com

### Abstract

Based on the identification of the problem, many Indonesian people, especially school children, are still not interested in reading activities. One of the efforts to increase interest in reading promoted by the government is to promote a reading corner program in schools. This study aims to determine the effect of the reading corner program in terms of the quality of the reading corner and the teacher's role in using the reading corner to increase the reading interest of fourth grade elementary school students in the Cijantung-East Jakarta area. By using survey research methods, the research instrument consists of 23 Questionnaire statement items were distributed to 4 schools consisting of 2 public elementary schools and 2 private elementary schools with a total sample of 233 students. Confirmatory Factor Analysis and Structural Equation Modeling (SEM) were performed to analyze instrument validation and test hypotheses. The results of the factor analysis showed that of the 23 instruments tested, there were 6 items that did not meet the requirements because they had an unqualified loading factor so that only 16 statements were used for analysis. The results of the SEM analysis show that the increase in reading interest is not dominantly influenced by the quality of the reading corner itself, but must be accompanied by the role of the teacher. These results indicate that the implementation of the reading corner program in schools is not only physically present but also must be supported by the role of the teacher.

**Keywords:** reading corner quality; reading interest; teacher role

### Abstract

Berdasarkan identifikasi masalah, masyarakat Indonesia khususnya anak sekolah masih banyak yang tidak berminat untuk melakukan kegiatan membaca. Salah satu upaya untuk meningkatkan minat baca yang digalakan pemerintah adalah dengan menggalakan program pojok baca di sekolah. Penelitian ini bertujuan untuk mengetahui pengaruh program pojok baca ditinjau dari kualitas pojok baca dan peran guru dalam memanfaatkan pojok baca tersebut terhadap peningkatan minat baca siswa kelas IV SD di wilayah Cijantung-Jakarta Timur. Dengan menggunakan metode penelitian survey, instrumen penelitian yang terdiri dari 23 butir pernyataan angket disebar terhadap 4 sekolah yang terdiri dari 2 SD Negeri dan 2 SD Swasta dengan jumlah sampel total 233 siswa. Confirmatory Factor Analysis dan Structural Equation Modeling (SEM) dilakukan untuk menganalisis validasi instrumen dan uji hipotesis. Hasil analisis faktor menunjukkan bahwa dari 23 butir instrumen yang diuji, terdapat 6 butir item yang tidak memenuhi syarat karena memiliki loading factor tidak memenuhi syarat sehingga hanya 16 butir pernyataan yang digunakan untuk analisis. Hasil analisis SEM menunjukkan bahwa dalam peningkatan minat baca tidak secara dominan dipengaruhi oleh kualitas pojok baca itu sendiri, namun harus di damping peran guru. Hasil ini menunjukkan bahwa pelaksanaan program pojok baca di sekolah bukan hanya sekedar menghadirkan pojok baca secara fisik namun juga harus ditunjang dengan peran guru.

**Kata Kunci:** kualitas pojok baca; minat baca; peran guru

Received : 2022-05-31

Approved : 2022-07-19

Revised : 2022-07-18

Published : 2022-07-31



Jurnal Cakrawala Pendas is licensed under a Creative Commons Attribution-ShareAlike 4.0 International License.

## Introduction

Education is something that a person uses to develop his abilities so that he can become a person who optimizes his life well and becomes a member of society whose life is guided by social moral values (Sudjana, 2004). In an effort to improve the quality of human resources in Indonesia, the government is working hard in the world of education, and has succeeded in getting satisfactory results in terms of education providers and even being able to read and write. Although this has indicated that the quality of education in Indonesia is good, Indonesia is still faced with a low reading level (Azmi, 2019). Indonesian people should be more aware of the importance of reading and start to make themselves interested in reading, to make themselves appear interested in reading Indonesian people must do the following habits: (1) Cultivate reading starting from the family environment, (2) Improve library services in the surrounding environment so that people can easily develop interest in reading, (3) the learning system in schools must continue to be updated in terms of increasing interest in reading from each student (Witanto, 2018).

If you don't follow these habits, Indonesian people will continue to be faced with a low level of reading interest. This is seen from The results of interviews with several elementary school teachers in the East Jakarta area obtained information that there were still many students who were less interested in reading. One of the effects of students' lack of interest in reading is because they are doing distance learning for too long. The Covid-19 pandemic has had an impact on human life, especially in the world of education (Baber, 2021). This change is not running optimally because educational institutions are not yet ready, therefore learning is carried out by e-learning (Haryudin & Imanullah, 2021). As a result, when learning e-learning (distance) students are always faced with technology when studying, students learn more by viewing learning videos than reading material in books or on the internet. As a result, when studying, students are accustomed to watching videos rather than reading, and this makes students less interested in reading. To overcome this problem, the solution is to make maximum use of the reading corner.

The reading corner has several advantages to increase interest in reading in students, such as students will be interested in reading because of its attractive design, it saves students time to read because they no longer have to go to the library, the atmosphere in the reading corner is very pleasant, and students will be more spending time in the reading corner instead of the canteen (Maharani T et al., 2020). Therefore, the reading corner can be used as a solution so that elementary school students can be interested in reading.

Internal factors that exist in students also have an effect on increasing reading interest in themselves. If there is no will in itself, and students assume reading activities are not interesting activities like when playing smartphones. Students who do not have an interest in reading are characterized by a low level of intelligence so that it will be difficult to read (Hapsari et al., 2019). And reading is also seen from one's background, because reading attitudes are strongly influenced by one's background (Coles & Hall, 2002). Therefore, the level of interest in reading from the Indonesian people is low, Indonesia is ranked below that of neighboring countries. This is reinforced by Central Connecticut State University research based on the study "Most Littered Nation In The World" in March 2016 that Indonesia was ranked 60th out of 61 countries regarding reading interest. This is a concern for the Indonesian people that reading culture is very important (Prasrihamni et al., 2022). Therefore, we play a role in making changes starting from the family environment and school environment, one of which is by creating a reading corner program so that children have an interest in reading (Rosalina et al., 2020). With

the support from all parties, families, and schools, as well as the trust and motivation of teachers during learning, students will experience an increase in reading interest. Because with the belief and motivation, it is a factor that is directly related to the internal conditions felt by students during the learning process (Baabdullah, 2018).

The reading corner is a facility for reading and storing books in the back corner of the classroom and arranged in a comfortable and attractive manner so that students can develop an interest in reading (AR Kurniawan et al., 2019). This is in line with Ministry of Education and Culture, 2016 Reading corner is a place to read with a complete collection of books and is located in the corner of the classroom as a function of extending the library. The reading corner has a purpose, namely so that students can increase interest in reading which is facilitated by readings that aim to introduce students to what kinds of readings can be used as learning materials and media that provide students with experience that reading is a fun activity (W. Kurniawan et al., 2021).

This reading corner activity is a positive student activity, where the activity of exchanging books is carried out by all students. The reading corner will look lively and interesting if the collection in the reading corner has a variety of reading books and has lots of reading books. This book exchange activity also allows students who do not have reading books to enjoy reading activities (Husna, 2020). So that the function of the reading corner can be described as follows: (a) To make students enjoy reading, (b) Students will easily get books such as story books and textbooks, (c) Students will be closer to books, (d) Learning activities can be easily supported because of the reading corner (Arum Nisma Wulanjani & Candradewi Wahyu Anggraeni, 2019). Reading corner indicators include: (1) Arrangement of book collections, (2) Lighting, (3) Air circulation, (4) Supporting facilities, (5) Relevance of books to needs, (6) Number of reading books, (7) Replacing collection of reading books, (8) Types of reading books (Anisafitri, 2018).

In the reading corner, what will be known is someone's interest in reading. Reading interest comes from two words, namely interest and reading. From an etymological sense, interest means liking, desire, or passion that is in the heart when doing an activity (Permatasari, 2018). Interest in reading is the best investment for students, because students will benefit from the interest that is formed in the learning process (Tarigan, 2018). Then the meaning of interest itself is a thing when learning activities are carried out with love and interest (Ama, 2020). Someone with a high reading interest will easily read the texts and there is no coercion when doing reading activities. Therefore, interest plays an important role in reading activities. The conclusion is based on the opinions above that understanding reading interest is an activity with full perseverance and tends to be carried out by a person so that someone can obtain information and find the meanings of the writings in the reading, this is so that someone can develop their abilities and intellectuals. This is done with joy and awareness and is carried out in lifelong learning.

Interest in reading is influenced by certain factors, supporting factors such as habits, a person's ability to read, and also the selected reading material. Then the inhibiting factors such as input or reinforcement that students have on the basis of teacher giving are lacking so that students are not enthusiastic in growing their reading interest, students are lazy to read, and students' lack of understanding of the importance of reading (Puspitaningrum, 2021). Therefore, the reading corner must be designed by the teacher as creatively as possible so that the reading corner becomes interesting and must also continue to motivate students so that students have an interest in reading. However, each student has a different personality, there are students who find it easy to increase interest in reading because they receive motivation from the teacher and

there are students who find it difficult to increase interest in reading because they do not understand the motivation of the teacher. Indicators of students' interest in reading include: (1) When reading books they feel happy, (2) Books become a necessity, (3) Interested in books, (4) Always want to read books, (5) Always look for books, (6) Reading frequency, (7) Quantity of reading sources (Dalman, 2014).

In order to foster student interest in reading, this requires the role of many parties, especially teachers. The teacher's role to increase students' reading interest, the ways are: (1) Providing a place to read in each class, this place is often called a reading corner, (2) Always communicating with students about what reading books should be in the collection. It is endeavored with children to discuss books well. This is so that children can be brave in expressing their opinions in terms of reading materials, (3) Students are given the opportunity to write stories related to their experiences, (4) Reading materials are adapted to the material in class, so that when reading students will gain knowledge according to the material, (5) Connecting the meter with the reading books in the reading corner collection (Faturrohman & Sulistyorini, 2012).

Indicators of the teacher's role in utilizing student reading corners are: (1) Promoting compulsory reading programs, (2) Providing synopsis/abstract assignments from books read, (3) Assigning students to read in their spare time, (4) Changing the system of teaching and learning activities (KBM) to motivate students to read, (5) Give special time to read, (6) Give assignments to read certain books, (7) Provide reading guidance, (8) Choose model students to read (Darmono, 2007).

Based on previous research, although there have been several studies on reading corners to increase students' reading interest, none of them have compared the quality of reading corners in public elementary schools and private elementary schools, especially in the Cijantung-East Jakarta area, and many researchers who conducted this study used qualitative method with interviews, not with quantitative methods with questionnaires. The purpose of this study is to see and compare how the quality of reading corners in public elementary schools and private elementary schools is in increasing students' reading interest.

## Research methods

The research method used is a quantitative research. The method used by the researcher is this survey method because in data collection the researcher seeks information rather than the respondents using a questionnaire/questionnaire with the number of instruments being 23 statements with a total of 233 samples. The existence of a large sample so that the research carried out can be maximized because the sample is a specific quality part that is chosen correctly to represent the population based on the research problem (Taherdoost, 2018).

The purpose of this study was to determine whether there is an effect of reading corners on increasing students' reading interest in elementary schools and to compare the effect of reading corners in private elementary schools and public elementary schools. The benefits of this research are to increase knowledge about reading corners, how to implement them, and the benefits for students, and it is hoped that it can provide benefits and insight into concepts related to reading corners to increase students' reading interest.

This research was conducted by distributing questionnaires to 4 schools in Cijantung Village, with 2 public schools and 2 private schools each. The complete number of respondents in this study can be seen in table 1.

**Table 1.** Number of student respondents

School name	Total students
SDN Cijantung 05 Pagi	64
SDN Cijantung 02 Pagi	63
SDK Ignatius Slamet Riyadi I	58
SDS Kartika VIII-1	48
<b>Total</b>	<b>223</b>

In this study, an instrument in the form of a survey questionnaire was used. This survey instrument was used to explore quantitative data on the variables of reading corner quality, teacher's role, and students' reading interest. Then the three variables were translated into 23 instrument items using a Likert scale of 1-4. The indicators for each of the 23 instrument items can be seen in table 2.

**Table 2.** Research variable indicators

Variable	Item Code	Item Indicator	Source
Reading Corner Quality	RC1	Book collection arrangement	(Anisafitri, 2018)
	RC2	Lighting	
	RC3	Air Circulation	
	RC4	Supporting facilities	
	RC5	Relevance of books to needs	
	RC6	Number of reading books	
	RC7	Types of reading books	
	RC8	Changing the collection of reading books	
Teacher's Role	TR1	Promote mandatory reading programs.	(Darmono, 2007)
	TR2	Give a synopsis/abstract assignment from the book read.	
	TR3	Assign students to read in their spare time.	
	TR4	Changing the teaching and learning system to encourage students to read	
	TR5	Give a special time to read	
	TR6	Give assignments to read certain books.	
	TR7	Provide reading guidance.	
	TR8	Selecting exemplary students in reading	
Interest in reading students	RI1	When reading a book feeling happy	(Dalman, 2014)
	RI2	Books are a necessity	
	RI3	Interested in books	
	RI4	Always wanted to read a book	
	RI5	Always looking for books	
	RI6	Reading frequency.	
	RI7	Quantity of reading sources.	

PLS (Partial Least Squares) SEM-VB (Structural Equation Modeling-Variance Based) by using the software SmartPLS 3.3.9 is used to test the research model where the data obtained must be entered into Microsoft Excel and saved in .CSV (Comma Delimited) format. The reason for using PLS-SEM is the latest analytical method that combines multiple regression and factor analysis, which is based on actual factors or facts, not just theoretical ones (Jonathan & Anondho, 2018).

**Results and Discussion**

This descriptive statistic displays data including the minimum and maximum scores, average, standard errors, kurtois, and skewness, as shown in table 3.

**Table 3.** Descriptive Statistics

Variable	Item Code	No.	Min	Max	mean	Stdev	Kurt.	Skew.
Reading Corner Quality	RC1	1	1	4	3.215	0.784	-0.081	-0.722
	RC4	2	1	4	3.009	0.859	-0.476	-0.507
	RC5	3	1	4	3.116	0.874	-0.105	-0.772
	RC6	4	1	4	2.931	0.938	-0.513	-0.585
	RC7	5	1	4	3.210	0.932	0.046	-0.990
Teacher's Role	TR1	6	1	4	2,961	0.991	-0.724	-0.535
	TR2	7	1	4	2,880	0.960	-0.708	-0.490
	TR3	8	1	4	2,631	1.045	-1.054	-0.192
	TR4	9	1	4	2,944	0.968	-0.647	-0.517
	TR5	10	1	4	2.828	1.022	-0.888	-0.477
Interest in reading students	TR8	11	1	4	2,515	0.985	-1.009	-0.150
	RI1	12	1	4	3464	0.687	0.962	-1.147
	RI2	13	1	4	3451	0.647	0.115	-0.865
	RI3	14	1	4	3356	0.745	0.560	-1,000
	RI4	15	1	4	3262	0.800	0.562	-0.914
	RI5	16	1	4	2987	0.876	-0.053	-0.629

Based on table 1, it can be seen that the survey instrument items are all distributed normal. This can be seen from the Skewnes and Kurtois values which are in the range of  $-1.96 < t < 1.95$ . If the tskew or ts Kurt values are not in that range, either only one or both, then the data is not normally distributed (Kuntoro, 2007).

Based on the results of the factor analysis of the survey instrument used, the results of the initial analysis are obtained as depicted in the structure of Figure 2.

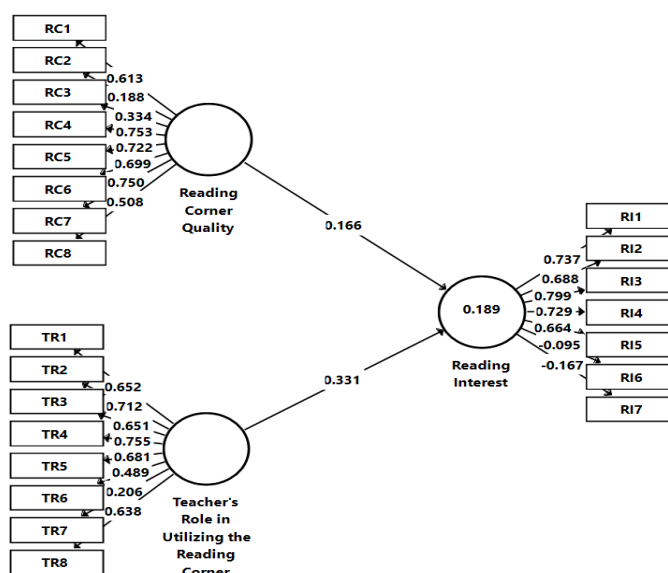

**Figure 2.** Initial Measurement Model Assessment

It can be seen from Figure 2 that there are 7 items that have a loading factor value of <0.5, namely RC2, RC3, RC8, TR6, TR7, RI6 and RI7 so that these items must be deleted. After the invalid items are discarded, the final validity value is obtained as shown in Figure 3.

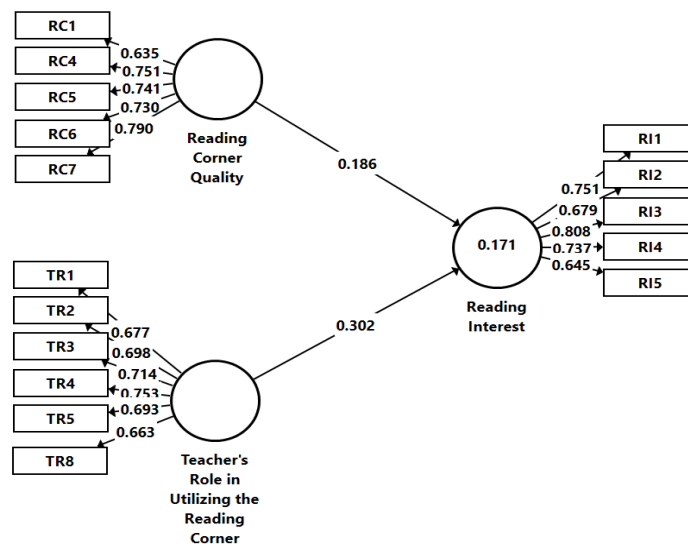

Figure 3. Final Measurement Model Assessment

In figure 3, seven items that do not meet the requirements have been deleted so that the statement items are left with 16 items as shown in table 4

Table 4. Convergence Validity

Construct	Item Code	Items	Outer Loading	AVE	CR	Cronbach's Alpha
RC	RC1	Book collection arrangement	0.635	0.535	0.851	0.785
	RC4	Supporting facilities	0.751			
	RC5	Relevance of books to needs	0.741			
	RC6	Number of reading books	0.730			
	RC7	Types of reading books	0.790			
TR	TR1	Promote mandatory reading programs.	0.677	0.538	0.847	0.774
	TR2	Give a synopsis/abstract assignment from the book read.	0.698			
	TR3	Assign students to read in their spare time.	0.714			
	TR4	Changing the teaching and learning system to encourage students to read	0.753			
	TR5	Give a special time to read	0.693			
	TR8	Selecting exemplary students in reading	0.663			
RI	RI1	When reading a book feeling happy	0.751	0.49	0.852	0.793
	RI2	Books are a necessity	0.679			
	RI3	Interested in books	0.808			
	RI4	Always wanted to read a book	0.737			
	RI5	Always looking for books	0.645			

Based on table 4, there are results that all constructs have a valid outer loading value because they range from 0.635 to 0.808, the condition that is declared valid is if it has a minimum outer loading value of 0.50 (Amam & Soetriono, 2020). Based on these results, it can be seen that the convergent validity indicator everything this has been realized because the values

of outer Loading, AVE, CR and Cronbach's alpha pass all parameters, therefore it can be concluded that all construct items in constructing each latent variable are valid instrument.

Besides Convergent Validity, another measure that shows construct validity is discriminatory validity. Discriminatory Validity includes the Heterotrait-Monotrait ratio and the Fornell & Lacker Criterion.

**Table 5.** *Discriminate Validity : Heterotrait-Monotrait Ratio*

	RC	TR	RI
RC			
TR	0.374		
RI	0.517	0.472	

Table 5 shows the Heterotrait-Monotrait ratio that is in accordance with the criteria. Because the Heterotrait-Monotrait ratio has a limit it must be less than 0.80 (Henseler et al., 2015).

**Table 6.** *Discriminator Validity: Fornell & Larcker Criterion*

	RC	TR	RI
RC	<b>0.731</b>		
TR	0.308	<b>0.726</b>	
RI	0.401	0.377	<b>0.7</b>

Table 6 is the Fornell & Larcker Criterion value where the root value of the AVE value is listed on the diagonal thick, while the other is the correlation coefficient (r). and shows that the AVE value of each variable studied is greater of the correlation between variables (Darmawan & Pamungkas, 2019). These results indicate that the criteria from the Fornell-Larcker analysis on discriminant validity are met.

Based on the results of all Confirmatory Factor Analysis (CFA) tests, it was found that the required criteria had been met so that it can be concluded that to test the hypothesis the proposed model can use 16 valid instruments.

For significant testing of the hypothesized model, one must look at the t-value, R2, and beta ( $\beta$ ) corresponding to the bootstrapping procedure with a re-sampling of 5,000. The R2 shows how well all the existing factors are (Ringle et al., 2015).

**Table 7.** *Structural Model Assessment*

Hypothesis	Path	Std. Beta	Std. Error	t- value	bias	Confidence Interval		desicion	R2
						2.50%	97.50%		
H1	RC -> RI	0.186	0.07	2,652	0.01	0.038	0.312	Supported	0.171
H2	TR -> RI	0.302	0.069	4.397	0.011	0.158	0.427	Supported	

Table 7 describes the results of testing the structural model which shows the results of hypothesis testing. Based on the test results obtained the results that the quality of the reading corner (=0.186, t=2.619) as well as the role of the teacher in utilizing the reading corner during the learning process (=0.302, t=4.378) positive and significant effect on increasing students' reading interest. Based on the value of R2, it can be concluded that the quality of the reading corner and the role of the teacher together affect the reading interest of fourth grade elementary school students in Cijantung Village by 17 percent.

With the emergence of the Covid-19 pandemic, students are faced with online learning, where learning to use smartphones and more are faced with watching YouTube or other learning platforms during teaching and learning activities (KBM), this makes students not



interested in reading while studying because they study more often. By watching, as a result, students are not interested in reading.

The main objective of this research is to build a conceptual model of the synergy between the quality of reading corners and the teacher's role in increasing students' reading interest. Based on the results of hypothesis testing of the 2 tested hypotheses, all of them (H1 and H2) were accepted. This gives the result that the reading corner and assisted by the role of the teacher can increase students' reading interest.

The synergy between the quality of reading corners and the teacher's role with increasing students' reading interest means that if you want to increase students' reading interest, the teacher must play a role in creating interesting reading corners and making students interested in reading activities. During this research I got data that there are several roles that teachers must play, such as increasing student interest in reading, the teacher's role can be done such as: (1) Providing interesting books according to the age of elementary school children, (2) Changing books in the reading corner at least once a week, (3) Include reading activities during the learning process, (4) Promote reading corner programs in their respective classes, (5) Give students assignments to note interesting things when students read books, (6) Provide special time for students, where students only focus on reading what books they like, and (7) Guiding students to read, this can make students feel interesting when reading with their own teacher. The teacher's role for students is to increase their reading interest, the teacher cannot let go of the reading corner, because the reading corner is the easiest means for students to come to read or get books other than the library. Therefore, the reading corner in every class or even in the corners of the school area must always be updated and preserved by all school parties so that students are interested in visiting it. because the reading corner is the easiest means for students to come to read or get books other than the library. Therefore, the reading corner in every class or even in the corners of the school area must always be updated and preserved by all school parties so that students are interested in visiting it. because the reading corner is the easiest means for students to come to read or get books other than the library. Therefore, the reading corner in every class or even in the corners of the school area must always be updated and preserved by all school parties so that students are interested in visiting it.

This also happened in previous research, namely the increase occurred because the teacher used the reading corner as much as possible by facilitating it as comfortably as possible, neatly, and attractively so that students could often visit the reading corner (AR Kurniawan et al., 2019). Subsequent research also explains that there is an increase in the use of reading corners, this increase can be done by making the lower classes get used to reading by reading guided search and reading silently in picture books. Then in high class reading is done by discussing, this will familiarize children to read (Ramandanu, 2019). Then further research got the results of increasing interest in reading in students by habituation to students such as reading 15 minutes before learning began, and taking spare time to go to the reading corner (Pradana, 2020). Subsequent research also obtained results that it could increase students' reading interest, this was done by means of all parties, both principals, teachers, and others optimizing the reading corner to the maximum (Fitriani, 2020). And the latest research to create an increase in reading interest, the supporting factor is the enthusiasm of students, as well as support from all the school parties, as well as decorations and excellent book collections that make students always visit the reading corner (Amiroh, 2020).

However, in previous studies, there was no comparison of the quality of reading corners in increasing students' reading interest in public elementary schools and private elementary schools. In this study found data that the quality of the reading corners in private elementary

schools has superior quality than public elementary schools, it is known from several teachers in private elementary schools that the reading corners in each class have quite a lot of funds, so as to create an interesting reading corner and students are interested in visiting it. While the role of teachers as educators who must guide students to read, teachers in public and private schools both have an equal role to create students' interest in reading.

## Conclusion

Based on research that reading corners have a positive effect on increasing interest in reading, but this must be accompanied by the role of the teacher. Support and guidance from the teacher is also important in reading activities in the reading corner, so that students can continue to be motivated in increasing their reading interest. From the quality of reading corners, it can be seen in this study that the quality of reading corners in private elementary schools is superior to that in public elementary schools, this is because the private sector has adequate costs. This finding can be a guide for pre-school educational institutions and elementary schools to seek to synergize the quality of reading corners and the role of teachers to increase students' reading interest. In the future, it is necessary to implement new findings to explore factors that can increase or hinder students' reading interest.

## Bibliography

- Ama, R. G. T. (2020). Membangun Minat Baca Pada Siswa Sekolah Dasar. In *CV: Pena Persada*.
- Amam, & Soetriono. (2020). Peranan Sumber Daya terhadap SDM Peternak dan Pengembangan Usaha Ternak Sapi Perah di Kawasan Peternakan Sapi Perah Nasional (KPSPN). *Jurnal Peternakan Indonesia*, 22(1), 1–10. <https://doi.org/10.25077/jpi.22.1.1-10.2020>
- Amiroh, S. (2020). Pemanfaatan Pojok Baca Dalam Meningkatkan Minat Baca Pada Siswa Kelas IV Di MI TAUFIQIYAH Semarang. *Universitas Islam Negeri Walisongo*, 43–54. <http://www.akrabjuara.com/index.php/akrabjuara/article/view/919>
- Anisafitri. (2018). *Pengaruh Penerapan Pojok Baca Di Sekolah Dasar terhadap Minat Baca Siswa*.
- Arum Nisma Wulanjani, & Candradewi Wahyu Anggraeni. (2019). Meningkatkan Minat Membaca Melalui Gerakan Literasi Membaca bagi Siswa Sekolah Dasar. *Proceeding of Biology Education*, 3(1), 26–31. <https://doi.org/10.21009/pbe.3-1.4>
- Azmi, N. (2019). Implementasi Gerakan Literasi Sekolah (GLS) di MI Negeri Kota Semarang Tahun Ajaran 2018/2019. *Universitas Tarbiyah Dan Keguruan*.
- Baabdullah, A. M. (2018). Consumer Adoption Of Mobile Social Network Games (M-SNGs) In Saudi Arabia: The Role Of Social Influence, Hedonic Motivation And Trust. *Technology in Society*, 5, 91–102. <https://doi.org/https://doi.org/10.1016/j.techsoc.2018.01.004>
- Baber, H. (2021). Modelling The Acceptance Of E-learning During The Pandemic Of COVID-19-A Study Of South Korea. *International Journal of Management Education*, 19(2), 1–15. <https://doi.org/https://doi.org/10.1016/j.ijme.2021.100503>
- Coles, M., & Hall, C. (2002). *Gendered Readings: Learning From Children's Reading Choices*.

*Journal of Research in Reading*, 25, 96–108.

- Dalman. (2014). keterampilan Membaca. *Jakarta: Rajawali Pers*, 145.
- Darmawan, D., & Pamungkas, A. S. (2019). Pengaruh Financial Attitude, Financial Behavior, Dan Financial Knowledge Terhadap Financial Satisfaction. *Jurnal Manajerial Dan Kewirausahaan*, 1(2), 172–181. <https://doi.org/10.24912/jmk.v1i2.5076>
- Darmono. (2007). *Perpustakaan Sekolah Pendekatan Aspek Manajemen Tata Kerja*. PT Grasindo.
- Faturrohman, M., & Sulistyorini. (2012). *Belajar Dan Pembelajaran: Meningkatkan Mutu Pembelajaran Sesuai Standar Nasional*. Penerbit Teras.
- Fitriani, A. (2020). Hubungan Antara Intensitas Program Pojok Baca Dengan Minat Baca Siswa Kelas VA Di MI Nashrud Fajar Tembalang Kota Semarang Tahun Ajaran 2019/2020. *Journal of Chemical Information and Modeling*, 21(1). <https://doi.org/10.1016/j.ssci.2020.104773%0A>
- Hapsari, Y. I., Purnamasari, I., & Purnamasari, V. (2019). Minat Baca Siswa Kelas V SD Negeri Harjowinangun 02 Tersono Batang. *Indonesian Journal Of Educational Research and Review*, 2(3), 371–178. <https://doi.org/10.23887/ijerr.v2i3.22634>
- Haryudin, A., & Imanullah, F. (2021). The Utilization of Kinemaster Applications in the Making of Multimedia Based Teaching Materials for English E-Learning in New Normal (Covid-19). *PROJECT (Professional Journal of English Education)*, 4(2), 341–352. <https://doi.org/https://doi.org/10.22460/project.v4i2.p341-352>
- Henseler, J., Ringle, C. M., & Sarstedt, M. (2015). A New Criterion For Assessing Discriminant Validity In Variance-Based Structural Equation Modeling. *Journal of the Academy of Marketing Science*, 43(1), 115–135.
- Husna, Z. (2020). Pemanfaatn Pojok Baca Kelas Dalam Peningkatan Gerakan Literasi Sekolah. *Ecodunamika*, 3(2).
- Jonathan, G., & Anondho, B. (2018). Perbandingan Antara Pls Sem Dan Analisis Faktor Untuk Identifikasi Faktor Pengaruh Eksternal Proyek. *JMTS: Jurnal Mitra Teknik Sipil*, 1(2), 123–132. <https://doi.org/10.24912/jmts.v1i2.2668>
- Kemendikbud. (2016). *Panduan pemanfaatan Dan Pengembangan Sudut Baca Kelas Dan Area Baca Untuk Meningkatkan Mutu Sekolah Dasar*.
- Kuntoro. (2007). Metode Statistik. In *Pustaka Melati*.
- Kurniawan, A. R., Destrinelli, Hayati, S., Rahmad, Riskayanti, J., Wasena, I. S., & Triadi, Y. (2019). Peranan Pojok Baca dalam Menumbuhkan Minat Baca Siswa Sekolah Dasar The Role Of The Reading Corner In FosteringElementary School Students ' Interest In Reading. *Jurnal Inovasi Pendidikan Dan Pembelajaran Sekolah Dasar*, 3(2), 48–57.
- Kurniawan, W., Sutopo, A., & Minsih. (2021). Implementasi Pojok Baca untuk Meningkatkan Minat Baca Siswa MI Muhammadiyah Kartasura. *PaKMas (Jurnal Pengabdian Kepada Masyarakat)*, 1(1), 37–42. <https://journal.yp3a.org/index.php/PaKMas>
- Maharani T, Ahmad, S., & Siregar, N. (2020). Upaya Guru Dalam Pemanfaatan Pojok Baca Untuk Menumbuhkan Minat Baca Siswa Di Kelas III Madrasah Ibtidaiyah Swasta Nurul

- Yaqin Simpang Sungai Duren Muaro Jambi. *Doctoral Dissertation, UIN Sulthan Thaha Saifuddin Jambi*.
- Permatasari, A. R. (2018). Pengaruh Program Reading Classroom Terhadap Minat Baca Siswa di Perpustakaan SD Negeri Badean 1 Bondowoso. *Jurnal Manajemen Pendidikan, 6*(3), 1–8.
- Pradana, F. A. P. (2020). Pengaruh Budaya Literasi Sekolah Melalui Pemanfaatan Sudut Baca Terhadap Minat Membaca Siswa Di Sekolah Dasar. *Jurnal Pendidikan Dan Konseling (JPDK), 2*(1). <https://doi.org/10.31004/jpdk.v1i2.599>
- Prasrihamni, M., Zulela, & Edwita. (2022). Optimalisasi Penerapan kegiatan Literasi Dalam Meningkatkan Minat Baca Siswa Sekolah Dasar. *Jurnal Cakrawala Pendas, 8*(1).
- Puspitaningrum, D. A. (2021). Analisis Minat Baca Pada Siswa SD Kelas Tinggi Di Kabupaten Purwakarta (Penelitian Studi Kasus Kelas V di SDN 2 Munjul Jaya Kabupaten Purwakarta Tahun Pelajaran 2020/2021). *Doctoral Dissertation, Universitas Pendidikan Indonesia*.
- Ramandanu, F. (2019). Gerakan Literasi Sekolah (GLS) Melalui Pemanfaatan Sudut Baca Kelas Sebagai Sarana Alternatif Penumbuhan Minat Baca Siswa. *Jurnal Mimbar Ilmu, 24*(1), 10–19. <https://doi.org/10.23887/mi.v24i1.17405>
- Ringle, C. M., Wende, S., & Becker, J.-M. (2015). *SmartPLS 3*. [www.smartpls.com](http://www.smartpls.com)
- Rosalina, V., Fernando, D., Saefudin, & Hikmatullah. (2020). Gerakan 5000 Donasi Buku dalam Upaya Membangun Budaya Literasi: Tahap 2. *Bantenese: Jurnal Pengabdian Masyarakat, 2*(2), 122–123. <https://doi.org/10.30656/ps2pm.v2i2.2445>
- Sudjana. (2004). Pembinaan Dan Pengembangan Kurikulum di Sekolah. *Bandung: Sinar Baru Algesindog*.
- Taherdoost, H. (2018). Sampling Methods in Research Methodology; How to Choose a Sampling Technique for Research. *SSRN Electronic Journal, 5*(2), 18–27. <https://doi.org/https://doi.org/10.2139/ssrn.3205035>
- Tarigan, N. T. (2018). Pengembangan Buku Cerita Bergambar Untuk Meningkatkan Minat Baca Siswa Kelas IV Sekolah Dasar. *Jurnal Curere, 02*(02), 141–152. <http://www.portaluniversitasquality.ac.id:5388/ojssystem/index.php/CURERE/article/view/157>
- Witanto, J. (2018). Minat Baca yang Sangat Rendah. *Jurnal Perpustakaan Librarian, 1*–23.